

Please route to:

<input type="checkbox"/> Service	<input type="checkbox"/> Init.
<input type="checkbox"/> Sales	<input type="checkbox"/>
<input type="checkbox"/> Parts	<input type="checkbox"/>



Date: **Septembre 27, 2005** Subject: **Storage Procedure for 2-Stroke Engine Equipped Vehicles** No. **2005-11**  
**REVISION => 1: NOVEMBER 3, 2005**

YEAR	MODEL	MODEL NUMBER	SERIAL NUMBER
2005	3D™ RFI	All	All
	GTI™ / GTI RFI / GTI LE		

**NOTE:** Refer to appropriate Sea-Doo *SHOP MANUAL* when servicing a Sea-Doo watercraft.

## ENGINE DRAINING

**Model(s):** *GTI 717*

- Check engine drain hose [1] (lowest hose of engine). Make sure there is no sand or other particles in it and that it is not obstructed so that water can exit the engine. Clean hose and fitting as necessary.

**CAUTION:** Water in engine drain hose must be free to flow out, otherwise water could be trapped in engine. Should water freeze in engine, severe damage will occur. Check engine drain hose for obstructions.

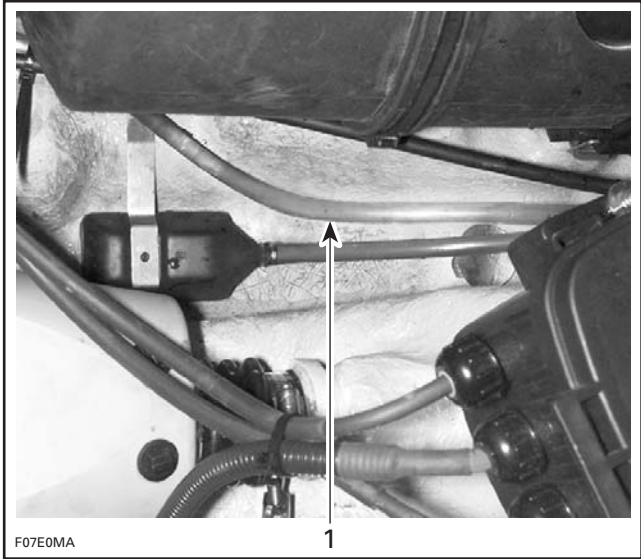

F07E0MA

1

**Model(s): GTI LE / GTI RFI**

- Disconnect the water supply hose used to cool the magneto. It features a quick connect fitting. Press both tabs [1] and pull fitting in order to disconnect hose. This hose is located at the bottom of the magneto cover beside the engine support.

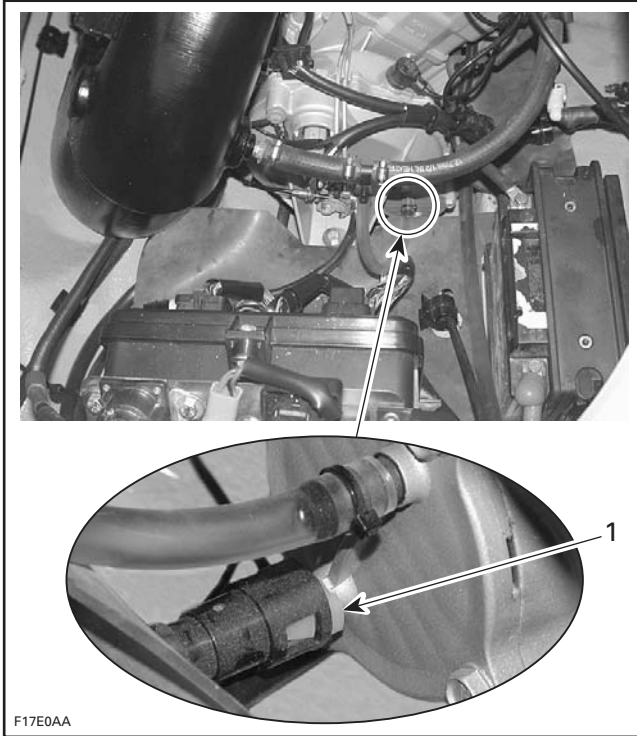

**Model(s): 3D RFI**

**NOTE:** It may be necessary to position the end of the hose in a lower area of the bilge to allow proper drainage.

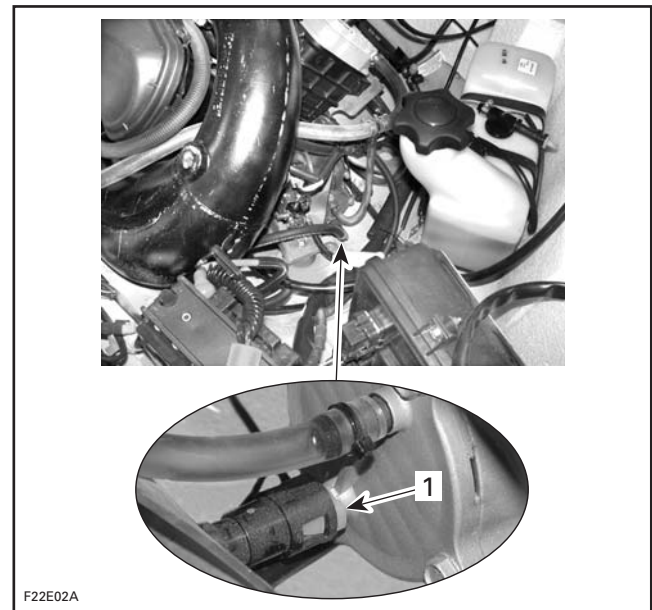

Water should flow out of the fitting [1] (magneto cooling circuit) and hose [2] (crankcase heat exchanger).

- Push and hold hose against bilge so that draining can take place.

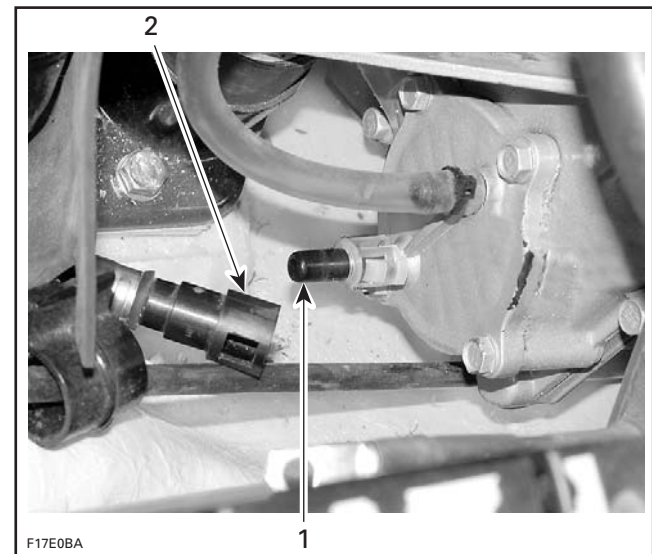

**CAUTION:** Water in heat exchanger system must be free to flow out. Should water freeze in engine, severe damage will occur.

- Reconnect hose when done.

## PROPULSION SYSTEM

### Jet Pump

Lubricant in impeller shaft reservoir should be drained. Reservoir should be cleaned and refilled with SEA-DOO synthetic 75W90 GL5 polyolester oil. Refer to JET PUMP in *SHOP MANUAL* for proper procedure.

**CAUTION:** Use only SEA-DOO jet pump oil or equivalent synthetic gear oil, otherwise component service life could be reduced. Do not mix oil brands or types.

### PTO Flywheel

- Remove PTO flywheel guard.
- Lubricate PTO flywheel at grease fitting [1] with synthetic grease (P/N 293 550 010).

**CAUTION:** Do not lubricate excessively. Stop immediately when a slight movement is noticed on rubber boot.

**CAUTION:** Never leave any clothing, tool or other objects near PTO flywheel and driveshaft.

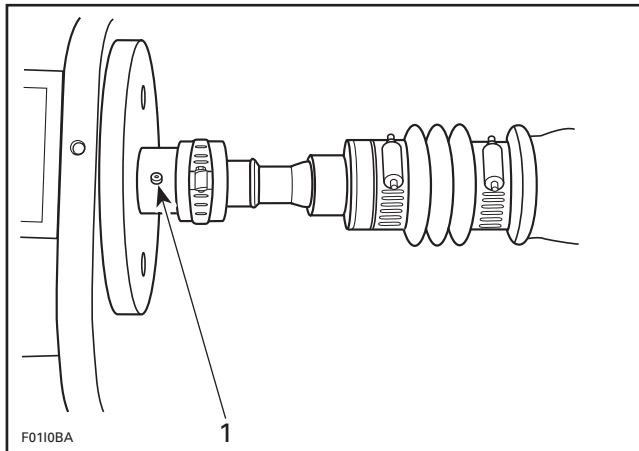

## Seal Carrier

**Model(s): 3D RFI**

- Lubricate seal carrier [1] of driveshaft support with synthetic grease. Stop lubricating when grease starts coming out of seal.

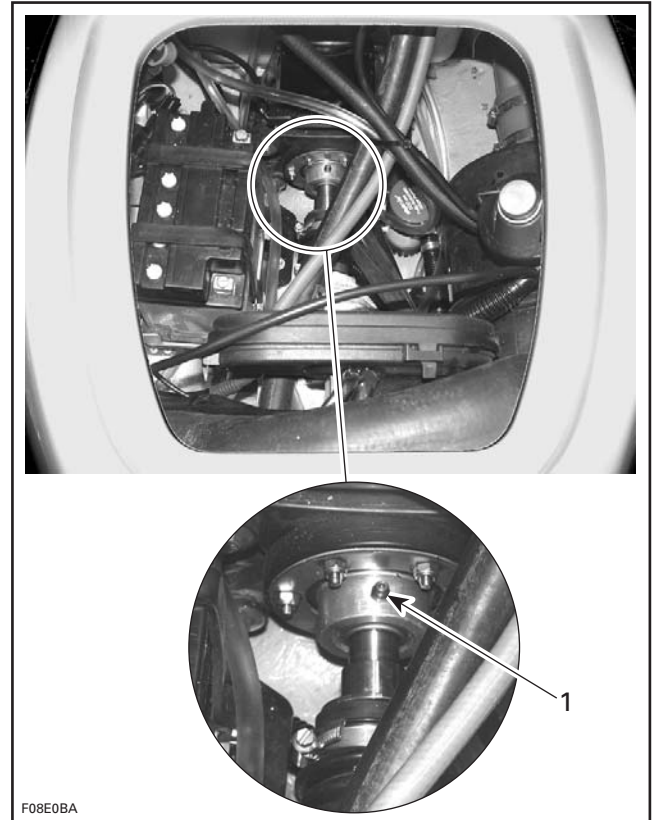

## FUEL SYSTEM

- Verify fuel system.
- Check fuel hoses and carburetor(s), if so equipped, for leaks.
- Replace damaged hoses or clamps if necessary.

**NOTE:** Sea-Doo Fuel Stabilizer (P/N 413 408 600) or equivalent should be added in fuel tank to prevent fuel deterioration and, if so equipped, carburetor(s) gumming. Follow manufacturer's instructions for proper use.

- Fill up fuel tank completely. Ensure there is no water inside fuel tank.

**CAUTION:** Should any water be trapped inside fuel tank, severe internal damage will occur to the fuel injection system (if so equipped).

**CAUTION:** Fuel stabilizer should be added prior to engine lubrication to ensure fuel system components protection against varnish deposits.

### **⚠ WARNING**

Fuel is flammable and explosive under certain conditions. Always work in a well ventilated area. Do not smoke or allow open flames or sparks in the vicinity. Fuel tank may be pressurized, turn cap slowly when opening. When fueling, keep watercraft level. Do not overfill or top off the fuel tank and leave watercraft in the sun. As temperature increases, fuel expands and might overflow. Always wipe off any fuel spillage from the watercraft. Periodically inspect fuel system. Always turn the fuel tank valve (**if so equipped**) to OFF position when storing the watercraft.

**Model(s): GTI 717**

- Always turn the fuel valve to OFF position when storing the watercraft.

## **COOLING SYSTEM FLUSHING**

Cooling system has to be flushed with fresh water to prevent salt, sand or dirt accumulation which will clog water passages.

For proper procedure, refer to FLUSHING in *SHOP MANUAL*.

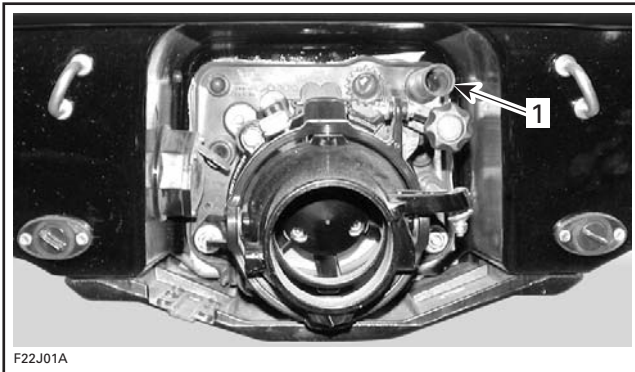

**NOTE:** On the 3D RFI, the hose adapter [1] is located on the right hand side on the jet pump support.

## **ENGINE INTERNAL LUBRICATION**

Engine must be lubricated to prevent corrosion on internal parts.

For proper procedure, refer to LUBRICATION in *SHOP MANUAL*.

## **BATTERY**

For battery removal, cleaning and storage, refer to the appropriate *SHOP MANUAL*.

## **WATERCRAFT CLEANING**

- Clean the bilge with hot water and mild detergent or with bilge cleaner. Rinse thoroughly. Lift front end of watercraft to completely drain bilge. If any repairs are needed to body or to the hull, touch up paint and Gelcote<sup>†</sup> repair kits are available. Replace damaged labels/decals.
- Wash the body with soap and water solution (use mild detergent only). Rinse thoroughly with fresh water. Remove marine organisms from the hull. Apply a nonabrasive wax.

**CAUTION:** Never clean fiberglass and plastic parts with strong detergent, degreasing agent, paint thinner, acetone, etc.

If the watercraft is to be stored outside, cover it with an opaque tarpaulin to prevent sun rays and grime from affecting the plastic components, watercraft finish as well as preventing dust accumulation.

**CAUTION:** The watercraft must never be left in water for storage. Never leave the watercraft stored in direct sunlight.

## **=> ANTIFREEZE PROTECTION**

In cool regions (where freezing point may be encountered), cooling system should be filled with pure undiluted antifreeze.

**CAUTION:** Antifreeze must be fed in cooling system, otherwise remaining water will freeze. If antifreezing is not performed adequately, engine/exhaust system may freeze and cause severe damage.

<sup>†</sup> Gelcote is a registered trademark of Gelcote International.

**CAUTION:** Use only undiluted antifreeze (100% concentration). The pre-mixed antifreeze available from Bombardier Recreational Products Inc. is not suitable for this particular application. Its concentration will be reduced when mixed with remaining water trapped in water jackets.

**NOTE:** Antifreeze must be compatible with internal combustion aluminum engines. It is recommended to use biodegradable antifreeze. This will contribute to protect the environment. Recreational vehicle (RV) antifreeze can be used.

**NOTE:** The engine will not have to run during this operation but should have been ran before, to exhaust as much water as possible, from cooling system components.

**Model(s): All GTI's**

**NOTE:** This procedure requires approximately 2.5 L (2.6 U.S. qt) of antifreeze.

Some hoses have to be plugged to prevent draining, before filling cooling system jackets with the antifreeze.

On vehicles equipped with the 717 engine, install hose pinchers on engine drain hose [1].

On vehicles equipped with 787 RFI engine, install hose pinchers on engine drain hose [1].

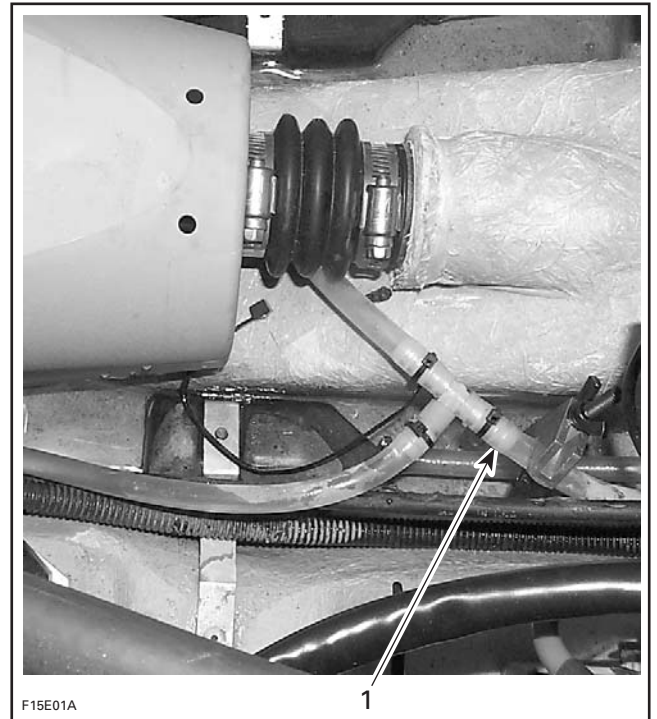

**NOTE:** On RFI models, make sure the hose [1] is properly connected to the magneto cover.

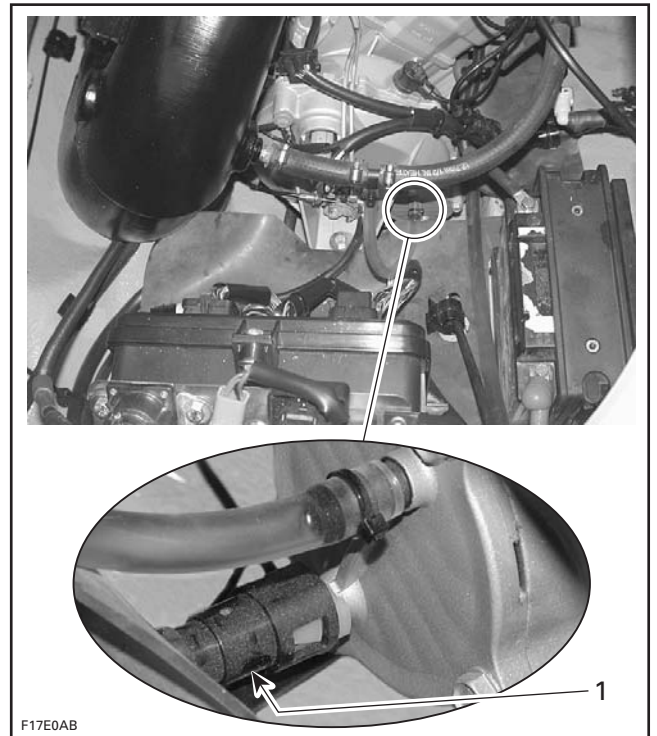
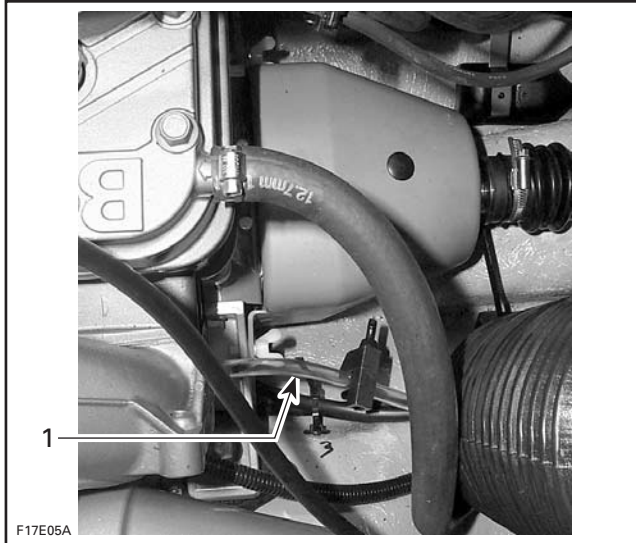

- On vehicles equipped with 717 engine, Install a hose pincher on injection hose [1] going to tuned pipe.

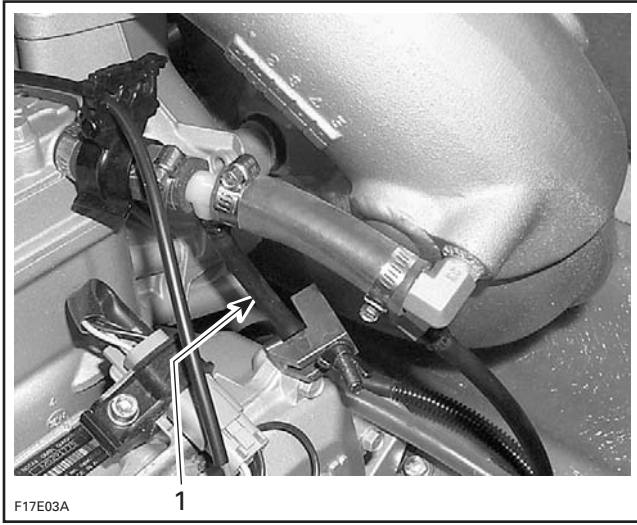
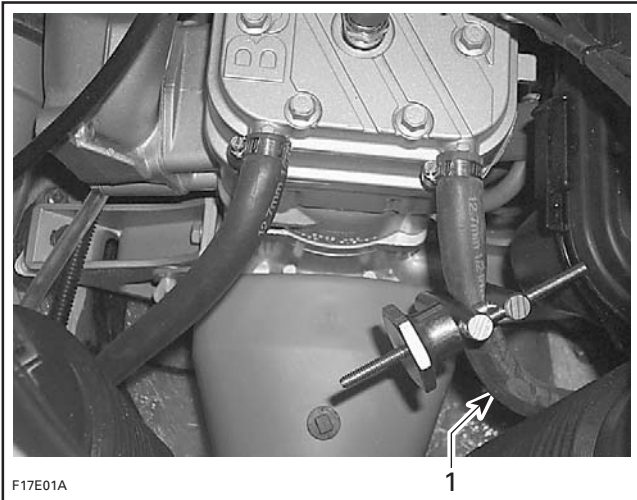
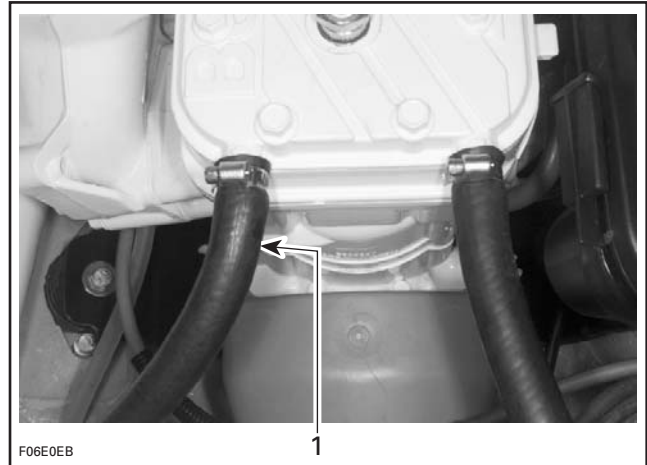

Photo shows engine water outlet hose [1], 717 and 787 RFI engines.



Disconnect water inlet hose [1], 717 and 787 RFI engines.



**Model(s): GTI 717**

- Temporarily install a short piece of hose to engine water inlet at cylinder head.

**Model(s): All GTI's**

- Insert a funnel into hose and pour antifreeze in engine until the colored solution appears at the cooling system bleed outlet.



**Model(s): 787 RFI Engines**

- Disconnect hose [2] just above T-fitting [1] as shown.

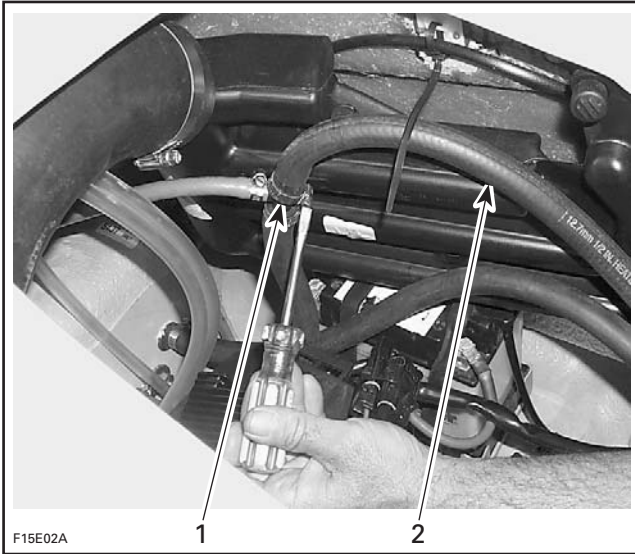

- Install a hose pincher [1] just below T-fitting.
- Pour approximately 300 mL (10 oz) of antifreeze in the water regulator valve supply hose to allow antifreeze flowing through the valve and into muffler to protect them.
- Reconnect hose to T-fitting and remove hose pincher (if applicable).

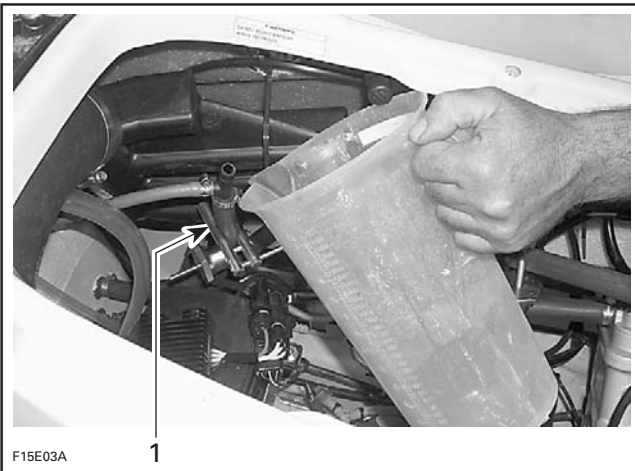

**Model(s): All GTI's**

- Remove temporary hose on 717 engines and reconnect engine water outlet hose.
- Remove hose pinchers.

Most of the antifreeze will drain out when removing the hose pinchers. Use a container

to recover it. DISPOSE ANTIFREEZE AS PER YOUR LOCAL LAWS AND REGULATIONS.

**NOTE:** Although antifreeze will mainly drain out, the antifreeze has mixed with the water that was possibly trapped in the water jackets and thus preventing freezing problems.

At preseason preparation, drain the remaining antifreeze from cooling system prior to using the watercraft. Ensure no hose pinchers were forgotten at storage.

**Model(s): 3D RFI**

**Engine and Tuned Pipe**

**NOTE:** This procedure requires approximately 2.5 L (2.6 U.S. qt) of antifreeze.

Remove rear access panel and engine cover. Lock steering pole in upright position with the holder.

**⚠ WARNING**

**Always install steering pole holder while working in the engine compartment.**

Install hose pinchers and disconnect hoses at the locations shown in photo, where [1] indicates the engine cylinder drain hose and [2] the heat exchanger drain hose.

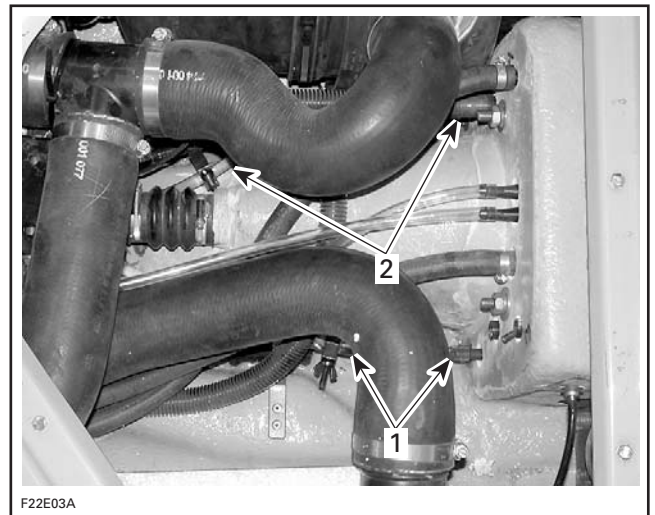

Disconnect water supply hose [1].  
 Pinch water outlet hose [2].  
 Install a temporary hose to engine fitting [3].

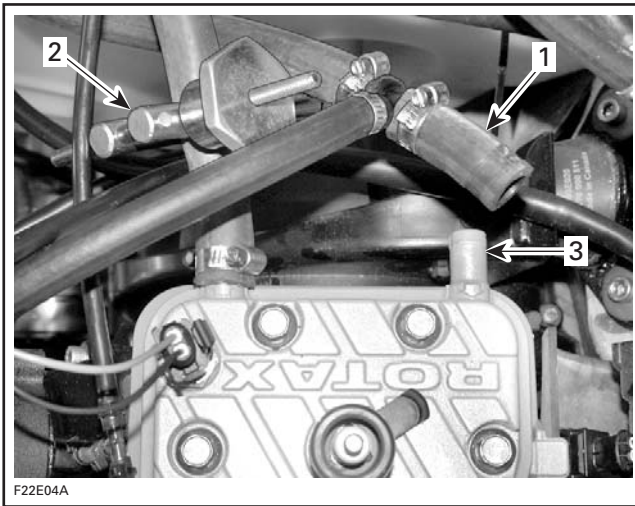

Place a container at rear of watercraft to recover the water/antifreeze from the vehicle hose adapter.

Remove the 2 hose pinchers from the engine drain hoses.

**NOTE:** Most of the antifreeze will drain out when removing the hose pinchers. Use a container to recover it. **DISPOSE ANTIFREEZE AS PER YOUR LOCAL LAWS AND REGULATIONS.**

#### Expansion Pipe and Muffler

Disconnect the tuned pipe water supply hose [1] at T-fitting.

Insert a funnel into the hose.

Raise the hose as high as possible and pour 1.2 L (1.3 U.S. qt) of antifreeze.

Insert a funnel into the temporary hose.



Pour antifreeze in engine until the colored solution appears at the cooling system bleed outlet [1]. Use a container to recover the water/antifreeze.

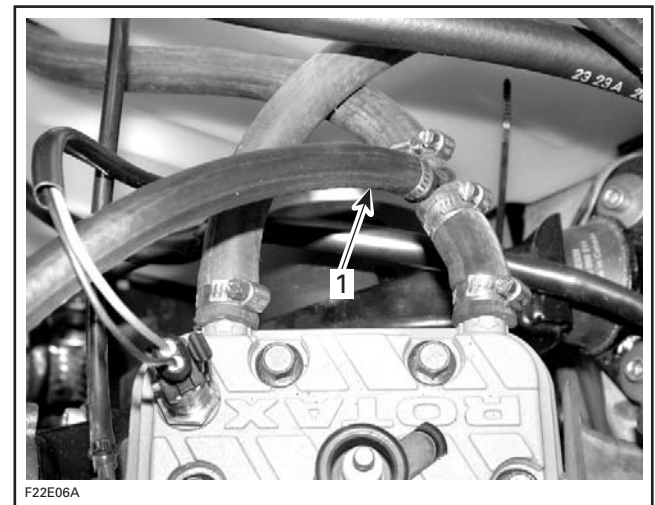

**CAUTION:** It is important to keep the hose as high as possible so the antifreeze can reach the end of the expansion pipe.

Reconnect hose to the T-fitting.

---

**NOTE:** For the above engine and exhaust system procedures, although antifreeze will mainly drain out, it has mixed with the water that was possibly trapped in the water jackets and thus preventing freezing problems.

At pre-season preparation, drain the remaining antifreeze from cooling system prior to using the watercraft. Ensure no hose pinchers were forgotten at storage.

Most of the antifreeze will drain out when removing the hose pinchers. Use a container to recover it. **DISPOSE ANTIFREEZE AS PER YOUR LOCAL LAWS AND REGULATIONS.**

## **ANTICORROSION TREATMENT**

- Wipe off any residual water in the engine compartment.
- Spray BOMBARDIER LUBE lubricant over all metallic components in engine compartment.
- Lubricate the throttle cable with BOMBARDIER LUBE lubricant.

**NOTE:** The seat should be partially left opened during storage (the engine cover for the XP DI models). This will avoid engine compartment condensation and possible corrosion.

## **CHECK LIST**

<b>OPERATION</b>	<b>✓</b>
Engine Draining	
Propulsion System: Jet Pump	
Propulsion System: PTO Flywheel	
Propulsion System: Seal Carrier	
Fuel system.	
Cooling System Flushing	
Engine Lubrication	
Battery	
Watercraft Cleaning	
AntifreezingProtection	
Anticorrosion Treatment	