

Please route to :

<input type="checkbox"/> Service	<input type="checkbox"/> Init.
<input type="checkbox"/> Sales	<input type="checkbox"/>
<input type="checkbox"/> Parts	<input type="checkbox"/>



No. **2000-13**  
**REVISION 1**

Date: December 15, 2000

**SUBJECT: Storage Procedure**

YEAR	MODEL	MODEL NUMBER	SERIAL NUMBER
2000	All	All	All

**NOTE:** Refer to appropriate *Sea-Doo® Shop Manual* or *Shop Manual Supplement* when servicing Sea-Doo watercraft.

**1. Engine Draining**

Check engine drain hoses (lowest hose from engine). Make sure there is no sand or other particles in them and that they are not obstructed so that water can leave the engine. Clean hoses and fittings as necessary.

**CAUTION:** Water in the engine drain hoses must be free to flow out, otherwise water could be trapped in the engine. Should water freeze in the engine, severe damage will occur. Always check the engine drain hoses for obstructions.

Special attention should be given to the GSX\* RFI, the GTX† RFI models and all models equipped with a 947 engine since water partially remains inside engine and cannot be totally drained. Refer to **Additional Recommended Protection** further in this bulletin.

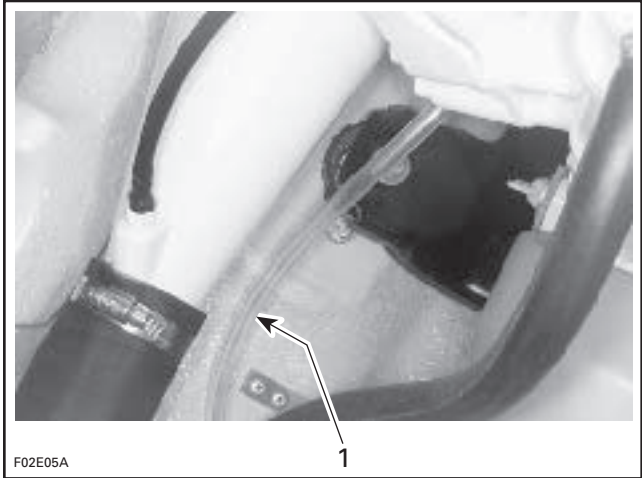

*TYPICAL — 717 ENGINE*  
1. Engine drain hose

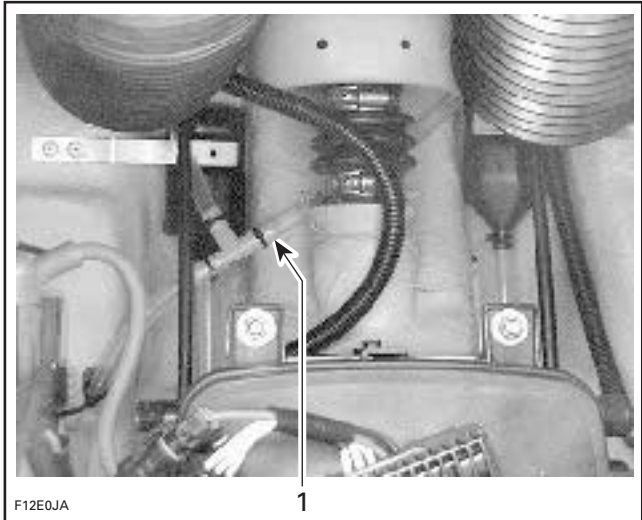

*RFI MODELS*  
1. Engine drain hose

† GTX is a trademark of Castrol Ltd. Used under license.

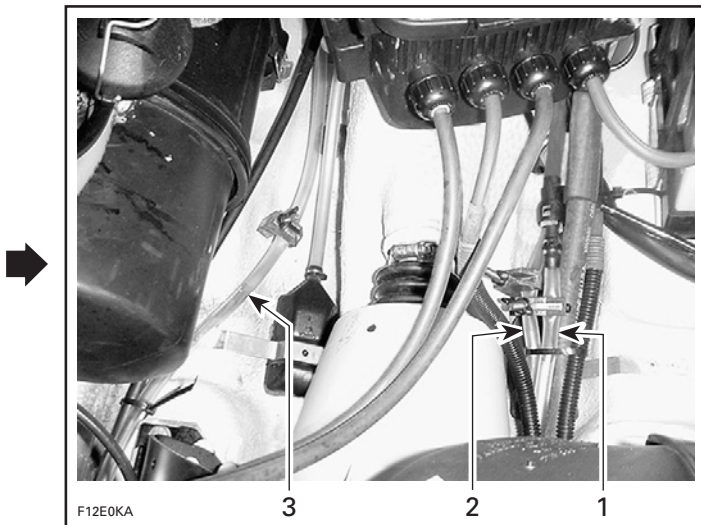

**DI MODELS**

1. Crankcase cooling outlet hose
2. Air pump cooling outlet hose
3. Engine cylinder/crankcase drain hose

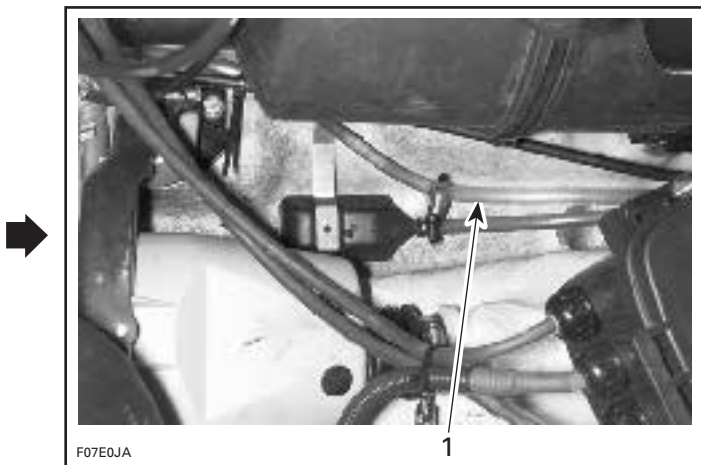

1. Cylinder drain hose (947 carb. model)

**GTX RFI and GSX RFI Models**

Disconnect the water supply hose used to cool the magneto. It features a quick coupling type fitting. Press both tabs and pull fitting to disconnect hose which is located at the bottom of the magneto cover near the engine support.

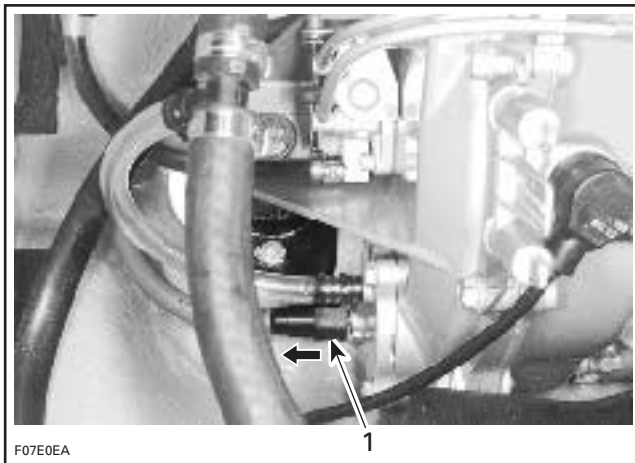

1. Disconnect this hose

Water should flow out the fitting (magneto cooling circuit) and hose (crankcase heat exchanger).

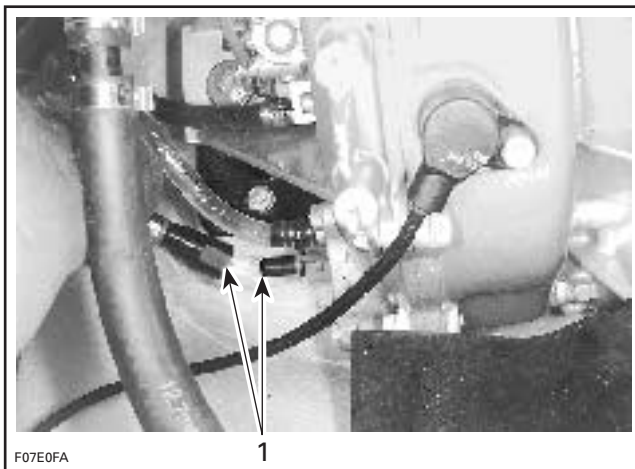

1. Make sure water flows out of fitting and hose

**CAUTION:** Water in heat exchanger system must be free to flow out. Should water freeze in engine, severe damage will occur.

Reconnect water supply hose to magneto heat exchanger.

## DI Models

Disconnect the quick connect fitting. Press both tabs and pull fitting.

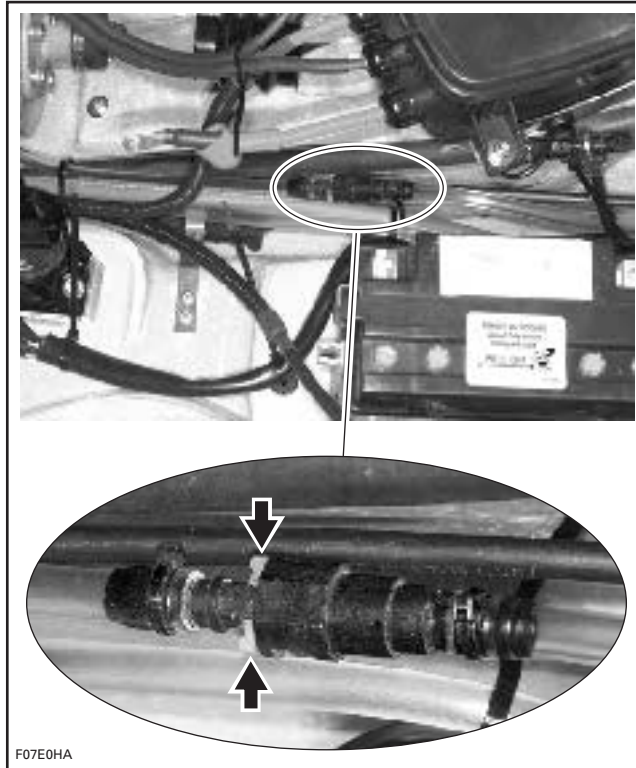

DISCONNECT THIS HOSE

Lower hose as necessary so that draining can take place.

Reconnect fitting when done.

Also ensure air compressor drain line is not obstructed. Clean as necessary.

## All Models

### 2. Fuel System

Add Sea-Doo fuel stabilizer (P/N 413 408 600) or equivalent, to the fuel tank to prevent fuel deterioration and, if so equipped, carburetor gumming. Follow the manufacturer's instructions for proper use.

Fill up fuel tank completely. Ensure there is no water inside fuel tank.

**CAUTION:** Should any water be trapped inside fuel tank, severe internal damage will occur to the fuel injection system.

**NOTE:** Fuel stabilizer should be added to the fuel before engine lubrication, to ensure that the carburetor, if so equipped, is protected against varnish deposits.

Verify fuel system. Check fuel lines and carburetor, if so equipped, for leaks. Replace damaged hoses or clamps if necessary.

## ⚠ WARNING

Fuel is flammable and explosive under certain conditions. Always work in a well ventilated area.

### 3. Cooling System Flushing

Flush the cooling system with fresh water to prevent salt, sand or dirt accumulation from clogging up water passages.

For proper procedure, refer to *Shop Manual*, FLUSHING AND LUBRICATION section.

### 4. Engine Internal Protection

Engine must be lubricated to prevent corrosion on internal parts.

Start the engine first then immediately open the water tap.

Run the engine about 3 minutes at a fast idle around 3500 RPM.

**CAUTION:** Never run engine longer than 5 minutes. The drive line seals have no cooling when watercraft is out of the water.

On 717 and 787 engine models, remove plug from air intake silencer cover. ←

Lubricate the engine to prevent corrosion on internal parts by spraying BOMBARDIER storage oil (P/N 413 711 600 (12 x 350 g)) through the hole provided on the air intake silencer cover.

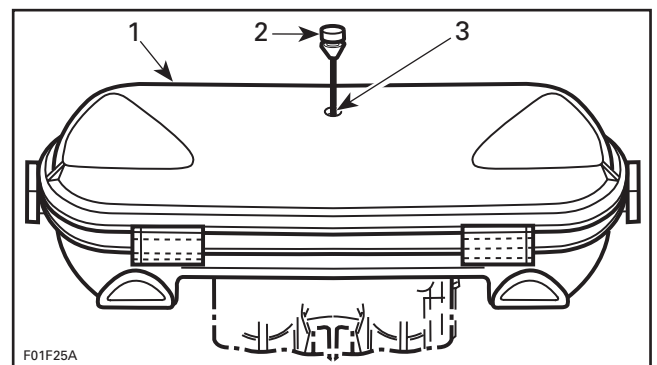

1. Air intake silencer cover
2. Remove plug
3. Spray BOMBARDIER storage oil here

On 947 DI models, attach red straw of Bombardier STORAGE OIL (P/N 413 711 600 (12 x 350 g)) bottle to white plastic adapter and spray Bombardier storage oil directly into the fogging tube adapter.



1. White plastic adapter

On models equipped with carbureted 947 engine, detach air silencer and spray BOMBARDIER storage oil directly into carburetors.

Lubricate the engine for one minute. After approximately half a minute, close fuel valve, if so equipped, to run engine out of fuel and turn off water flow to the engine.

**CAUTION:** When engine begins to run irregularly because of fuel starvation, immediately stop water flow before engine dies. Severe engine damage could result if not done in this order.

Stop the engine.

Reinstall the plug in air intake silencer cover or push the fogging tube back into the air box (where applicable).

## 5. Propulsion System

### Jet Pump

Lubricant in impeller shaft reservoir should be drained out and the reservoir cleaned.

Refill with Sea-Doo jet pump synthetic oil (P/N 293 600 011). Refer to CAPACITIES section from Technical Data of appropriate *Shop Manual* for proper quantity.

**CAUTION:** Use only SEA-DOO jet pump oil or equivalent synthetic gear oil, otherwise component service life could be reduced. Do not mix oil brands or types.

### PTO Flywheel

#### All Models Except XP\*

Remove PTO flywheel guard.

Lubricate PTO flywheel at grease fitting with synthetic grease (P/N 293 550 010).

**CAUTION:** Do not lubricate excessively. Immediately stop when a slight movement is noticed in the rubber boot.

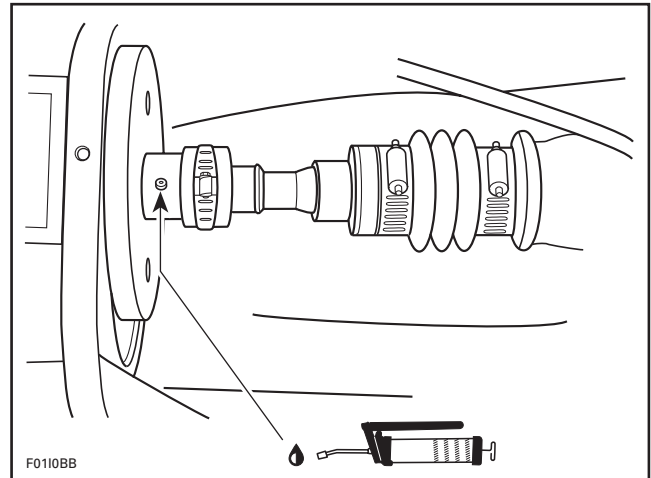

ALL MODELS EXCEPT XP

**CAUTION:** Never leave any clothing, tool or other objects near PTO flywheel and seal carrier.

### Seal Carrier

#### XP Model

Lubricate mid bearing of drive system at seal carrier grease fitting with synthetic grease. Stop lubricating when grease is just coming out of seal.

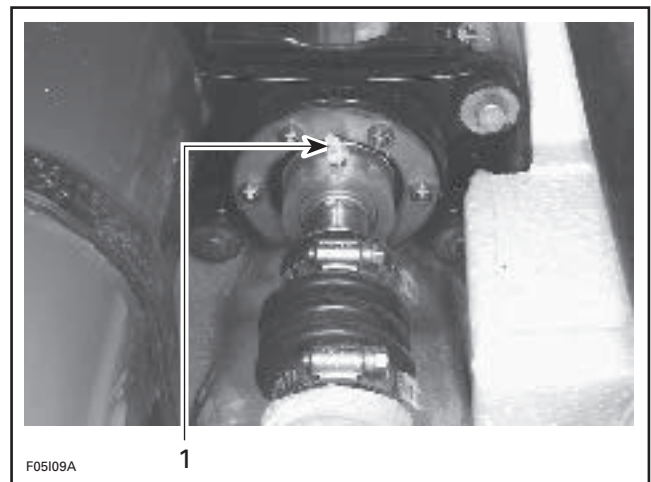

1. Grease fitting

## 6. Battery

For battery removal, cleaning and storage, refer to the appropriate *Sea-Doo Shop Manual* (ELECTRICAL SYSTEM).

## 7. Anticorrosion Treatment

Wipe off any residual water in the engine compartment.

Spray BOMBARDIER LUBE (P/N 293 600 016) over all metallic components in engine compartment.

Lubricate the throttle and oil injection cables with BOMBARDIER LUBE.

**NOTE:** A cable luber can be used on throttle cable end to inject BOMBARDIER LUBE.

## 8. Watercraft Cleaning

Clean the bilge with hot water and mild detergent or with bilge cleaner. Rinse thoroughly. Lift front end of watercraft to completely drain bilge. If any repairs are needed to body or to the hull, touch up paint and Gelcote® repair kits are available. Replace damaged labels/decals.

Wash the body with soap and water solution (only use mild detergent). Rinse thoroughly with fresh water. Remove marine organisms from the hull. Apply a non abrasive wax.

**CAUTION:** Never clean apparent fiberglass and plastic parts with strong detergent, degreasing agent, paint thinner, acetone, etc.

## 9. Additional Recommended Protection

In cool regions (where temperature below freezing point may be encountered), antifreeze solution made of 40% water and 60% antifreeze should be added to the cooling system.

**CAUTION:** Remaining water in cooling system will freeze. Either antifreeze must be added or water must be expelled with compressed air. This operation requires a good technical knowledge of the cooling system path. If antifreezing is not performed adequately engine/exhaust system may freeze and cause severe engine damage. Always use ethylene glycol antifreeze containing corrosion inhibitors specifically recommended for aluminum engines.

**NOTE:** The engine will not have to run during this operation.

## Water and Antifreeze Method

### 717 Engine

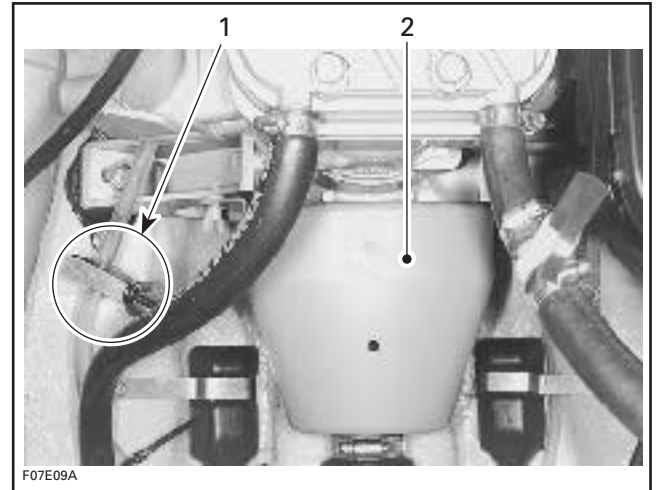

TYPICAL — 717 ENGINE

1. Hose pincher installed on engine drain hose
2. PTO flywheel guard

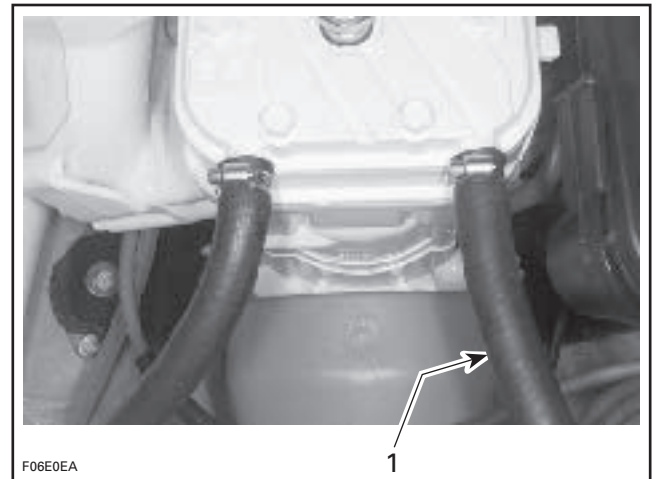

717 ENGINE

1. Disconnect engine water outlet hose

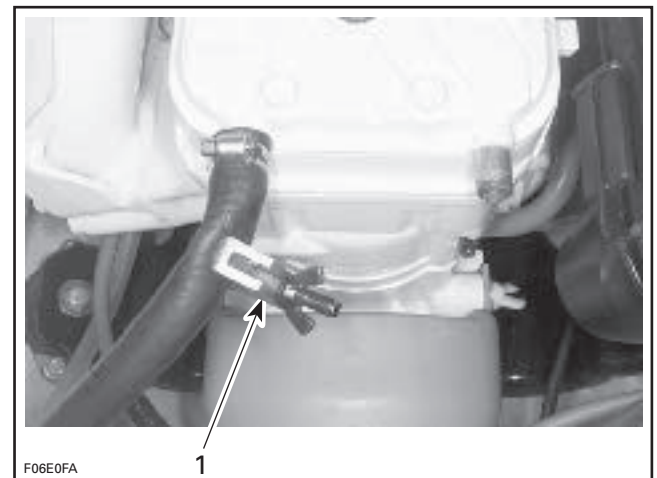

717 ENGINE

1. Install hose pincher on the engine water supply hose

## Antifreeze

Temporarily install a short piece of hose to engine water outlet at cylinder head.

Insert a funnel into hose and pour antifreeze mixed with water (40% water, 60% antifreeze) in engine until the colored solution appears in the engine drain hose.

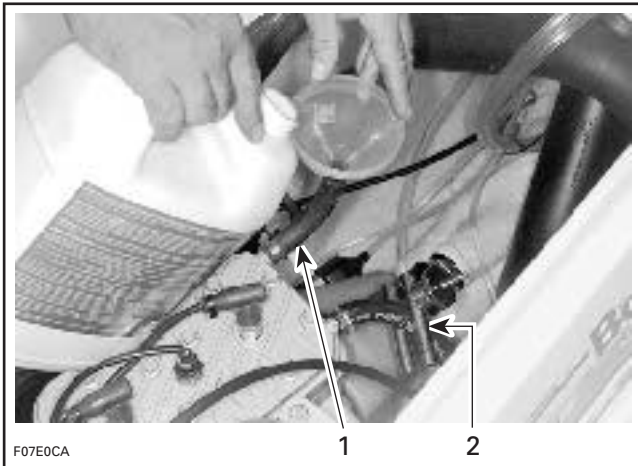

### TYPICAL

1. Hose and funnel installed at water outlet on cylinder head
2. Hose pincher installed on water supply hose

Remove temporary hose and reconnect engine water return hose.

Remove hose pinchers.

## 787 RFI Engine

Make sure the water supply hose from crankcase heat exchanger is connected to the magneto cooling system.

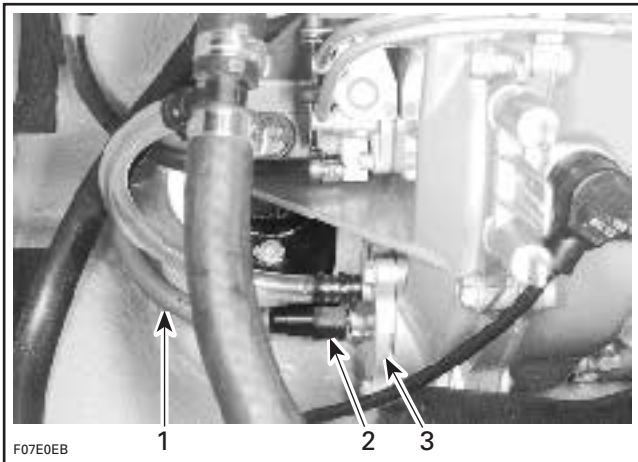

1. Water supply hose from crankcase heat exchanger
2. Quick connector
3. Magneto heat exchanger

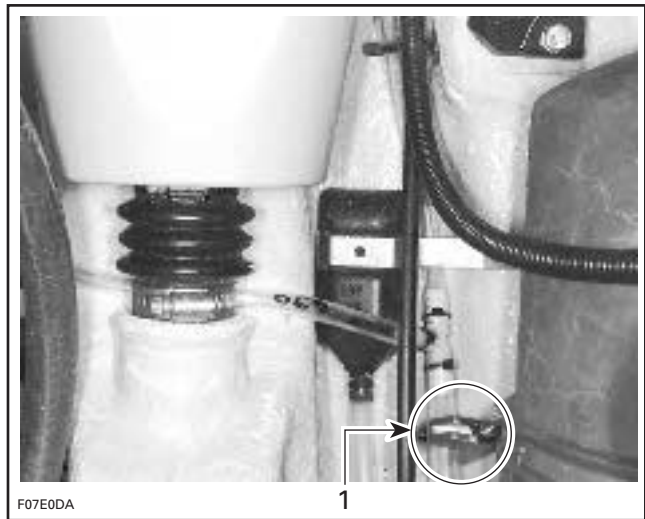

### RFI MODELS — 787 ENGINE

1. Install hose pincher on engine drain hose

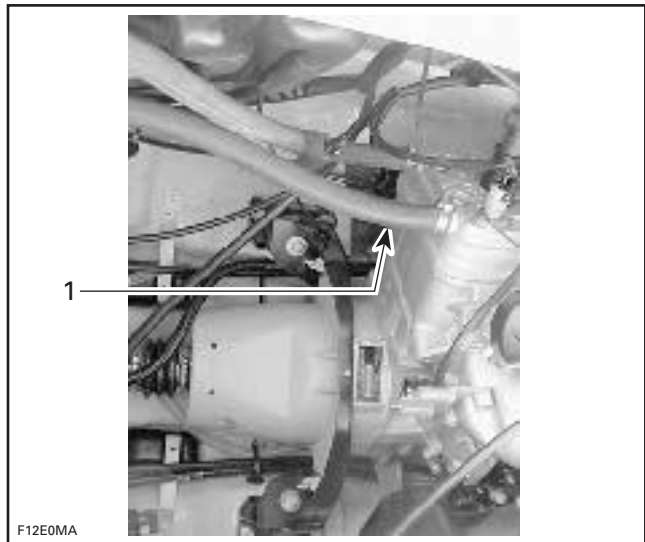

### 787 RFI ENGINE

1. Disconnect engine water return hose

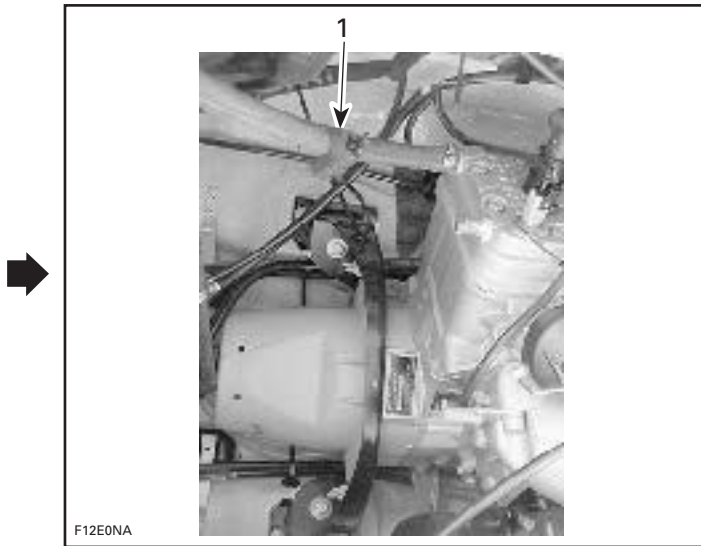

F12E0NA

**787 RFI ENGINE**

1. Install hose pincher on the engine water inlet hose

**Antifreeze**

Temporarily install a short piece of hose to engine water outlet at cylinder head.

Insert a funnel into hose and pour antifreeze mixed with water (40% water, 60% antifreeze) in engine until the colored solution appears in the engine drain hose.

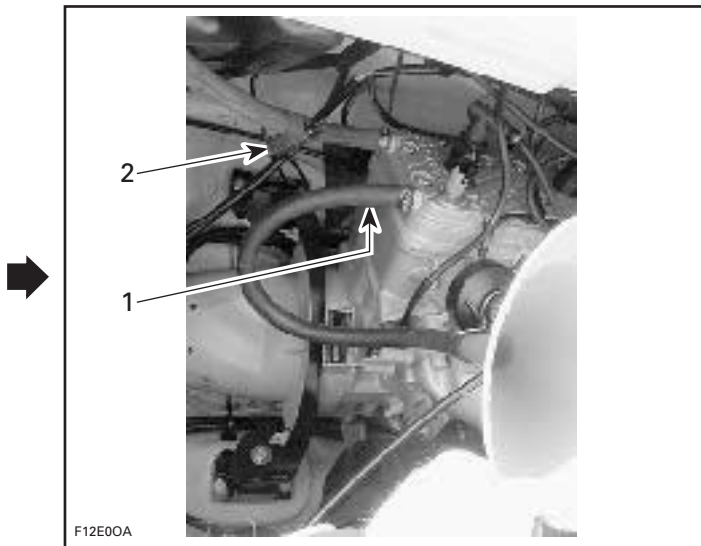

F12E00A

**TYPICAL**

1. Hose and funnel installed at water outlet on cylinder head
2. Hose pincher installed on water supply hose

Remove temporary hose and reconnect engine water return hose.

Remove hose pinchers.

**947 Engine with Carburetors**

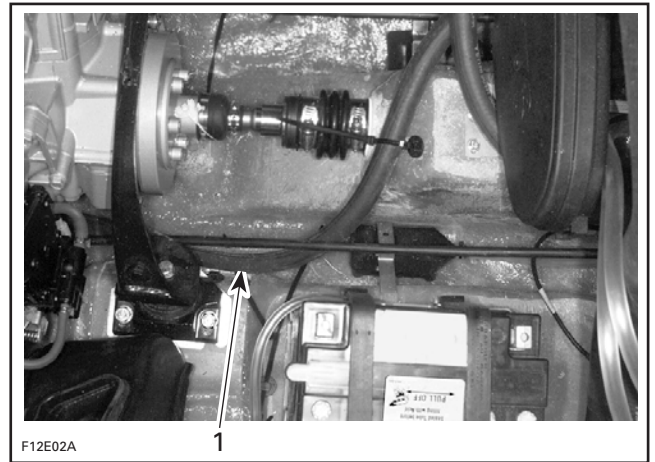

F12E02A

1. Install hose pincher on water outlet hose

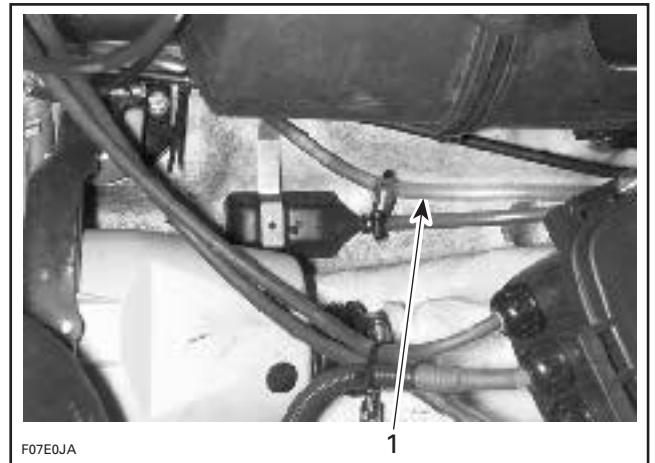

F07E0JA

1. Install hose pincher on engine cylinder drain hose

**NOTE:** On XP model, open rear cover to have access to engine drain hose.



F08E04A

**XP MODEL — 947 ENGINE**

1. Hose pincher installed on engine drain hose

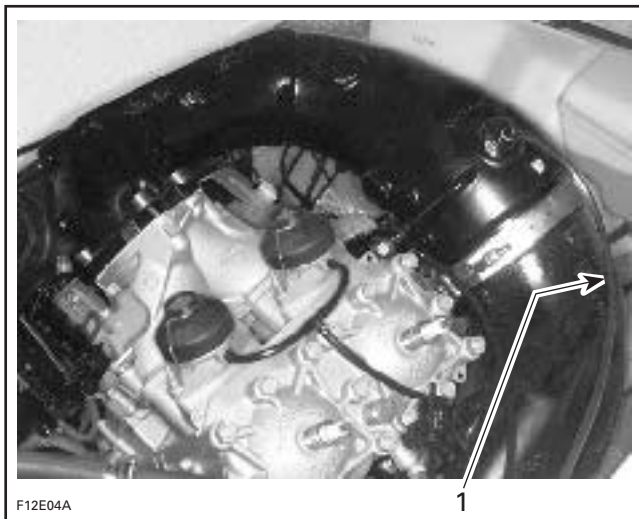

1. Install hose pincher on tuned pipe bleed hose

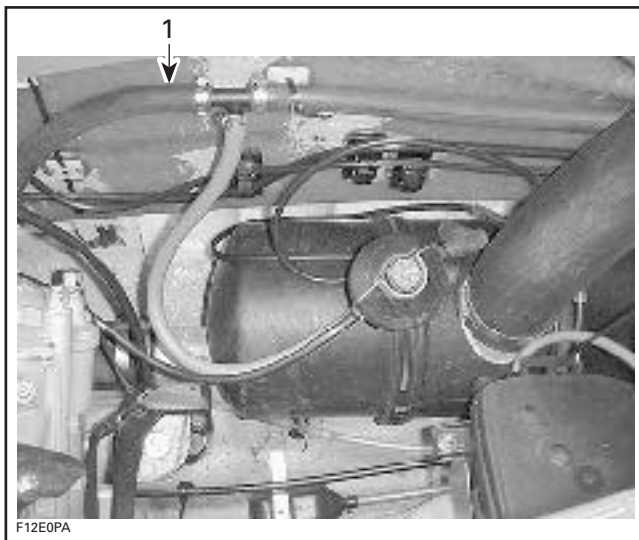

1. Disconnect water inlet hose this side of T-fitting

## Antifreeze

Insert a funnel into hose and pour antifreeze mix in engine until the colored solution appears at cooling system bleed outlet (LH side of hull; REAR for GTX).



At this point, remove the hose pincher at tuned pipe bleed hose. If necessary, continue to pour antifreeze mix until the colored solution appears at the other cooling system bleed outlet (stern eye-let).

Remove the remaining hose pinchers in this order to allow proper flow of antifreeze.

1. Engine cylinder drain hose.
2. Water outlet hose.

Pour approximately 200 mL (7 oz) of antifreeze in the water regulator valve supply hose to allow antifreeze flowing through the valve and into muffler to protect it.

Reconnect hose to T-fitting.

## DI Models

Install hose pinchers at the following 4 locations:

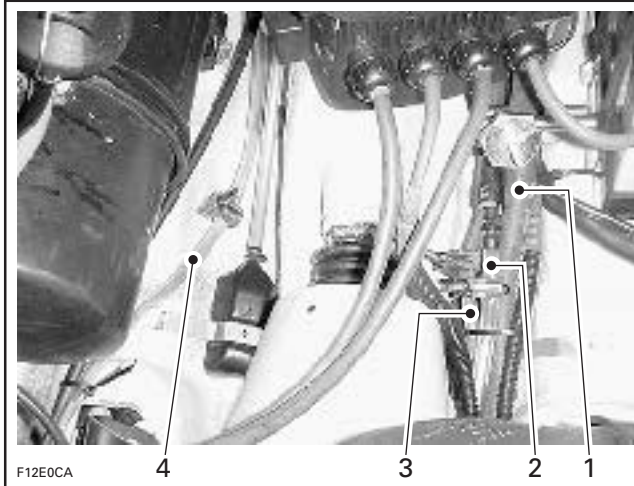

1. Water outlet hose
2. Crankcase cooling outlet hose (be sure quick connector is connected)
3. Air pump cooling outlet hose
4. Engine cylinder/crankcase drain hose

Disconnect water INLET hose before the T fitting which supplies the MAG cover cooling inlet hose.



1. Disconnect hose here

Temporarily install a short piece of hose to replace the one disconnected.

## Antifreeze

Insert a funnel into the temporary hose and pour antifreeze mix into the cooling system until the colored solution appears at the CSI (Cooling System Indicator) outlet.



At this point, install a hose pincher on the CSI hose.



1. Pincher installed on the CSI (Cooling System Indicator) hose

Continue to pour antifreeze mix (approximate capacity 2.3 to 2.4 L) until you can visually verify the colored solution at the following locations:

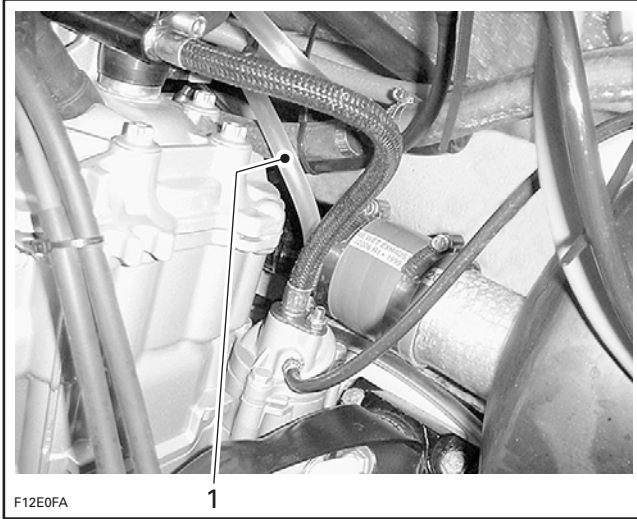

1. Air compressor inlet hose

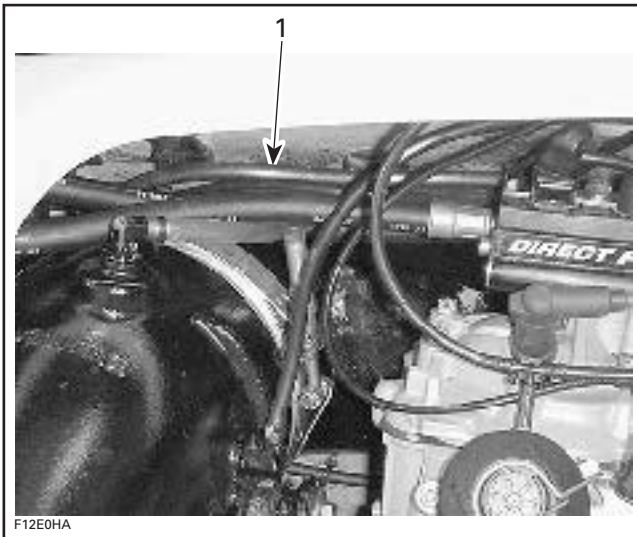

1. MAG cover cooling inlet hose (between T fitting and MAG cover)

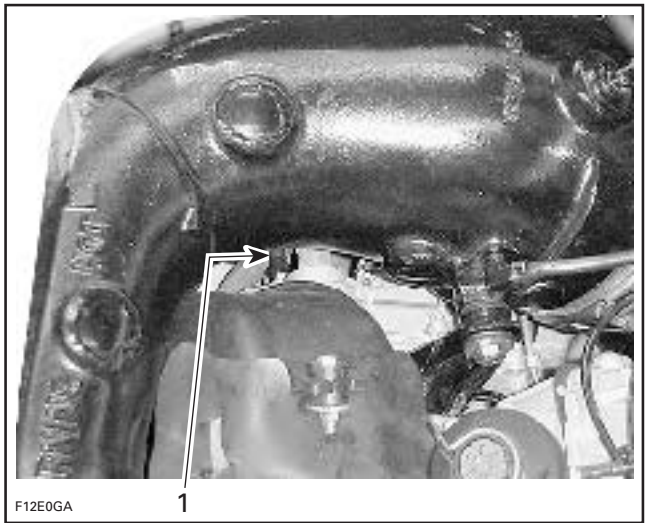

1. MAG cover cooling inlet hose (further down at MAG cover)

Remove pinchers in the following order to allow proper flow of antifreeze mix.

1. CSI hose.
2. Air compressor outlet hose.
3. Crankcase cooling outlet hose.
4. Cylinder/Crankcase drain hose.
5. Water outlet hose.

Pour approximately 200 mL (7 oz) of antifreeze mix into the supply hose for the water regulator. This will allow the antifreeze mix to protect the regulator valve as well as the muffler during storage.

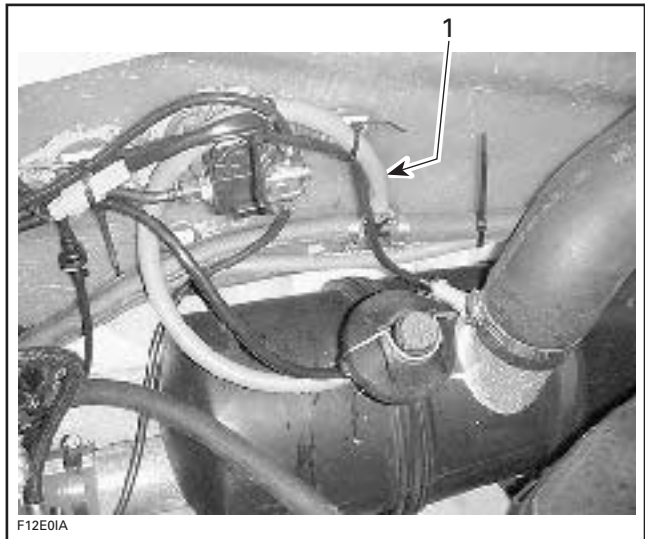

1. Regulator supply hose

Remove temporary hose and reconnect engine outlet hose.

### All Models

Most of the antifreeze will drain out when removing hose pinchers. Use a container to recover it. DISPOSE ANTIFREEZE AS PER YOUR LOCAL LAWS AND REGULATIONS.

**NOTE:** Although antifreeze will mainly drain out, the antifreeze has flowed to mix with water that was possibly trapped in cooling system cavities and thus preventing freezing problems.

Special attention should be given to the GTX RFI and all models equipped with a 947 engine since water partially remains inside engine and cannot be totally drained.

**NOTE:** For pre-season preparation, drain antifreeze from cooling system prior to launching watercraft in water as explained above.

### 10. Storage

If the watercraft is to be stored outside, cover it with an opaque tarpaulin to prevent sun rays and grime from affecting the plastic components, watercraft finish and dust accumulation.

**CAUTION:** The watercraft must never be left in the water for storage. Never leave the watercraft stored in direct sunlight.

The seat should be partially left open during storage. For the XP, leave the engine cover partially open. This will avoid condensation and possible engine corrosion.

**NOTE:** Remove the rear drain plug(s). Tilt the watercraft to the rear so that water can flow out.

## CHECKLIST

OPERATION	✓
Check engine drain hose(s)	
Add Sea-Doo fuel stabilizer	
Verify fuel system	
Flush the cooling system	
Lubricate the engine	
Drain and clean impeller shaft reservoir	
Lubricate PTO flywheel or seal carrier	
Remove, clean and store the battery	
Clean the bilge	
Wash the body	
Spray BOMBARDIER LUBE over all metallic components in engine compartment and on throttle and oil injection cables	
Add antifreeze solution to the cooling system (in cool regions)	